

# *Interactions between large organic cations and cation exchange membranes*

TOSHIKATSU SATA, KUNIAKI TAKATA, YUKIO MIZUTANI

*Research and Development Laboratory, Tokuyama Soda, Co., Ltd, 1-1, Mikage-cho, Tokuyama, Yamaguchi, 745, Japan*

Received 28 May 1984; revised 2 January 1985

Interactions between cation exchange membranes and large organic cations have been studied; namely (1) adsorption and electro-dialytic desorption of cationic surface active agents, and (2) change in transport properties of the membranes by adsorption.

N-dodecyl pyridyl compounds, such as N-dodecyl pyridinium bromide ( $C_{12}$ -Py), N-dodecyl dipyridyl bromide ( $C_{12}$ -Dipy) and N-dodecyl tripyridyl bromide ( $C_{12}$ -Tripy) were used for the adsorption and electro-dialytic desorption; and for the study on the change in transport properties of membranes, N-dodecyl pyridinium chloride,  $C_{12}$ -Py,  $C_{12}$ -Dipy,  $C_{12}$ -Tripy and hexadecyl trimethylammonium chloride were used. It was confirmed that the higher the molecular weight of the cation the longer the time required to reach adsorption equilibrium, and that the amount of adsorption exceeded the ion-exchange capacity of the membrane. After equilibrium was attained, electro-dialytic desorption from the membranes was difficult.

The adsorption or ion-exchange of large organic cations was effective to the permselectivity of the cation exchange membrane to the sodium ion in electro-dialysis of a solution of sodium chloride and calcium chloride. The relationship between the permselectivity and the properties of the cations was examined.

## 1. Introduction

Interactions between ion exchange membranes and large organic ions have been studied [1-6]. It has been previously reported [2] that a cation exchange membrane is converted into its bipolar type and then into its amphoteric type as the adsorption or ion-exchange of cationic surface active agents proceeds on the membrane. The bipolar type cation exchange membrane is more permeable to monovalent cations than to multi-valent cations [1].

Fouling of ion exchange membranes by large organic ions such as ionic surface active agents is a serious industrial problem in electro-dialysis, although the development of anti-organic fouling membranes has been reported [7-10]. On the other hand, it has been reported [11] that a ruthenium-bipyridine complex was adsorbed on cation exchange membranes and the electro-

chemical property of modified electrodes was studied.

Thus, it is of considerable interest to study the adsorption and electro-dialytic desorption of large organic cations and the change in properties of the membranes. Mainly N-alkyl pyridyl derivatives were used for the experiments.

## 2. Experimental details

### 2.1. Materials

*2.1.1. Cation exchange membrane.* The cation exchange membranes of NEOSEPTA CL-25T used for the experiments were manufactured by Tokuyama Soda Co., Ltd. by the 'Paste Method' [12-15]. The characteristics of the membrane are shown in Table 1. The membranes were equilibrated in a mixture of 0.208 N sodium chloride and 0.208 N calcium chloride in water or a

Table 1. Characteristics of the cation exchange membrane, NEOSEPTA CL-25T

Type	Strongly acidic
Backing	cation exchange Polyvinyl chloride
Thickness (mm)	0.16
Electrical resistance ( $\Omega \text{ cm}^2$ )*	2.8
Transport number <sup>†</sup>	> 0.98
Water content <sup>†</sup>	0.34
Ion-exchange capacity <sup>§</sup>	1.80
$K_{\text{Na}}^{\text{Ca}}$ <sup>¶</sup>	4.58

\* Equilibrated with 0.500 N NaCl solution and measured using 1000 cycle a.c. at 25.0°C.

<sup>†</sup> Measured by electro dialysis using 0.500 N NaCl solution current density: 20 mA  $\text{cm}^{-2}$ ; at 25.0°C.

<sup>‡</sup> Equilibrated with 0.500 N NaCl solution, g  $\text{H}_2\text{O}$ /g Na-form dry membrane.

<sup>§</sup> Mequiv/g Na-form dry membrane.

<sup>¶</sup> The equivalent ratio of  $\text{Ca}^{2+}$  to  $\text{Na}^+$  in the membrane when the membrane was equilibrated with the 1:1 solution of 0.208 N NaCl and 0.208 N  $\text{CaCl}_2$ .

0.416 N sodium chloride solution before experiments.

2.1.2. *Large organic cations.* Hexadecyl trimethylammonium chloride, dodecyl pyridinium chloride and dodecyl pyridinium bromide ( $\text{C}_{12}\text{-Py}$ ) were of reagent grade (Tokyo Kasei

Kogyo Co., Ltd.) and washed with ethyl ether before use. N-dodecyl dipyrindyl bromide ( $\text{C}_{12}\text{-Dipy}$ ) was synthesized: 7 parts of  $\alpha, \alpha'$ -dipyridine were dissolved in 150 parts of nitromethane, and 23 parts of dodecyl bromide were added; after the mixture had been refluxed for 72 h, it was placed in a vacuum for evaporation and an oily material was obtained; on washing with ethyl ether, light brown crystals were obtained. N-dodecyl tripyridyl bromide ( $\text{C}_{12}\text{-Tripy}$ ) was also synthesized with  $\alpha, \alpha', \alpha''$ -tripyridine and dodecyl bromide in the ratio of 7 parts to 35 in the same way as above. Elementary analysis of large organic cations used is shown in Table 2.



## 2.2. Measurements

### 2.2.1. Adsorption and electro dialytic desorption.

The effect of the immersion period, during which a membrane was immersed in a solution of large organic cations, on the properties of the membrane was studied. The immersion periods with  $\text{C}_{12}\text{-Py}$ ,  $\text{C}_{12}\text{-Dipy}$  and  $\text{C}_{12}\text{-Tripy}$  varied from 46 min to 20 days.

The adsorption was carried out as follows: cation exchange membranes of  $24.5 \text{ cm}^2$  ( $3.5 \text{ cm} \times 7.0 \text{ cm}$  each) were immersed in a

Table 2. Elementary analysis of N-dodecyl derivatives of pyridine,  $\alpha, \alpha'$ -dipyridine,  $\alpha, \alpha', \alpha''$ -tripyridine and other large organic cations used in this work

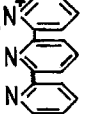
Compounds	Molecular formula		C	H	N	Cl or Br
N-dodecyl pyridinium chloride	$\text{C}_{12}\text{H}_{25}\text{N}^+$  $\text{Cl}^-$	Calculated	71.93	10.65	4.93	12.49
		Found	72.44	10.92	4.74	11.90
N-dodecyl pyridinium bromide	$\text{C}_{12}\text{H}_{25}\text{N}^+$  $\text{Br}^-$	Calculated	62.19	9.21	4.27	24.34
		Found	61.52	9.82	4.12	24.54
N-dodecyl $\alpha, \alpha'$ -dipyridyl bromide	$\text{C}_{12}\text{H}_{25}\text{N}^+$  $\text{Br}^-$	Calculated	65.18	8.21	6.91	19.71
		Found	64.42	8.33	6.73	20.58
N-dodecyl $\alpha, \alpha', \alpha''$ -tripyridyl bromide	$\text{C}_{12}\text{H}_{25}\text{N}^+$  $\text{Br}^-$	Calculated	67.21	7.52	8.71	16.56
		Found	67.33	7.85	8.13	16.69
cetyl trimethylammonium chloride	$\text{C}_{16}\text{H}_{33}\text{N}^+$ $(\text{CH}_3)_3 \text{Cl}^-$	Calculated	71.31	13.23	4.38	11.09
		Found	71.12	13.42	4.35	11.12

100 ml aqueous solution of  $0.0025 \text{ mol l}^{-1}$  or  $0.008 \text{ mol l}^{-1}$  of  $C_{12}$ -Py,  $C_{12}$ -Dipy or  $C_{12}$ -Tripy with stirring at  $25^\circ \text{C}$  for different periods. The amount,  $\Delta m$ , adsorbed on or ion-exchanged with each membrane was calculated from the amount remaining in the aqueous solution, which was obtained by means of ultraviolet absorption spectroscopy at a wavelength of 260 nm. The membranes were then washed with pure water and their transport properties were measured. After the electro dialysis, the amount,  $\Delta m'$ , desorbed from the membrane was determined by the analysis of both anolyte and catholyte.

N-dodecyl pyridinium chloride and hexadecyl trimethylammonium chloride were further adsorbed on the same membrane under similar conditions in order to evaluate the change in electrochemical property of the membrane. The concentration was changed keeping the immersion period constant, or the immersion period was changed keeping the concentration constant.

**2.2.2. Electrochemical properties.** The following were determined.

(a) Ratio of the transport number of sodium ion to that of calcium ion: the relative transport number,  $P_{\text{Na}}^{\text{Ca}} = (t_{\text{Ca}}/t_{\text{Na}})/(C_{\text{Ca}}/C_{\text{Na}})$ , where  $t_{\text{Ca}}$  and  $t_{\text{Na}}$  are the transport numbers of calcium ions and sodium ions in the membrane, and  $C_{\text{Ca}}$  and  $C_{\text{Na}}$  are the concentrations of calcium ions and sodium ions in the solution before electro dialysis.

(b) Current efficiency: *c.e.*, (%).

(c) Electric resistance of the membrane during the electro dialysis:  $R(\Omega \text{ cm}^2)$ .

After a cation exchange membrane had been immersed in an aqueous solution of large organic cations, it was placed in a cell shown in Fig. 1, which had two compartments. As soon as the two compartments had each been filled with a 120 ml aqueous solution of 0.208 M sodium chloride and 0.208 M calcium chloride, electro dialysis was started with a current density of  $10 \text{ mA cm}^{-2}$  and was continued for 60 min at  $25.0^\circ \text{C}$  with stirring at a rate of  $1500 \pm 100 \text{ r.p.m.}$  After the electro dialysis, the concentrations of chloride ion and calcium ion in

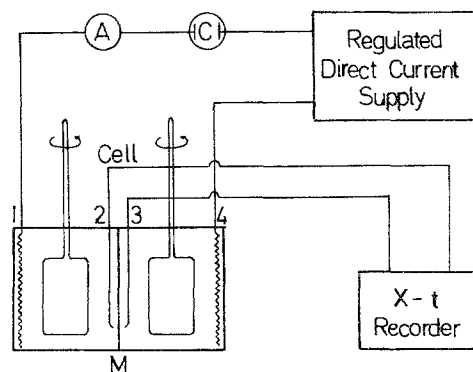

Fig. 1. Equipment used in the measurement of transport properties of cation exchange membrane. A, ammeter; M, cation exchange membrane; C, coulometer; 1 and 4, Ag-AgCl plate electrodes; 2 and 3, Ag-AgCl wire probe electrodes.

both the compartments were determined, and then  $P_{\text{Na}}^{\text{Ca}}$  and the current efficiency were calculated. The total current was measured by means of a coulometer. The voltage drop across the probe electrodes was recorded by an  $x-t$  recorder during the electro dialysis. The electric resistance of the membrane during the electro dialysis was calculated by subtracting the voltage drop measured without the membrane from that measured with the membrane.

### 3. Results and discussion

#### 3.1. Adsorption and electro dialytic desorption of N-dodecyl pyridyl bromides

Fig. 2 shows the relationship between the amounts of  $C_{12}$ -Py,  $C_{12}$ -Dipy and  $C_{12}$ -Tripy adsorbed on or ion-exchanged with cation exchange membranes of NEOSEPTA CL-25T and the immersion period. The bulkier the hydrophilic group, the longer the period required to attain adsorption equilibrium. N-dodecyl pyridyl compounds were selectively adsorbed or ion-exchanged, but with  $C_{12}$ -Tripy an equilibrium was attained after 20 days ( $2.88 \times 10^4 \text{ min}$ ) immersion. When all the cations in the solution are completely adsorbed or ion-exchanged,  $\Delta m$  is equal to  $5.10 \times 10^{-6} \text{ mol cm}^{-2}$  of each compound. The pHs of the N-dodecyl pyridyl compound solutions were about 3.5–4.0. As the  $pK_a$ s of  $\alpha$ ,  $\alpha'$ -dipyridine and  $\alpha$ ,  $\alpha'$ ,  $\alpha''$ -tripyridine

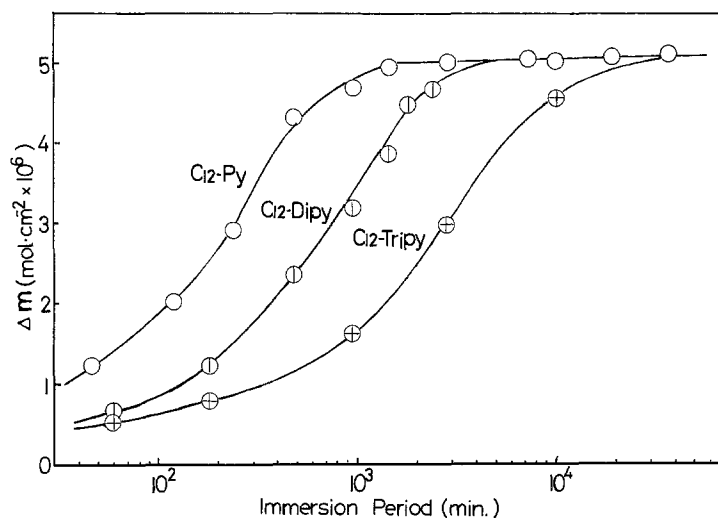

Fig. 2. Relationship between adsorbed or ion-exchanged amount of various N-dodecyl pyridyl compounds and immersion period. Concentration  $2.5 \times 10^{-3} \text{ mol l}^{-1}$ .

are 4.12 and 4.35 at  $25^\circ \text{C}$  respectively [16], tertiary amino groups of the compounds were protonated in these measuring conditions. The number of pyridyl groups of  $\text{C}_{12}$ -Tripy cohered on the membrane is equivalent to about 1.27 times the number of cation exchange groups of the membrane of NEOSEPTA CL-25T which is about  $1.2 \times 10^{-5} \text{ mol cm}^{-2}$ . In order to confirm the adsorption or ion-exchange of N-dodecyl pyridyl compounds in excess of the ion-exchange capacity of the membrane, the same measurements were made with aqueous solutions of  $0.008 \text{ mol l}^{-1}$   $\text{C}_{12}$ -Py and  $\text{C}_{12}$ -Dipy. The results are shown in Fig. 3. Although the amount of  $\text{C}_{12}$ -Dipy adsorbed or ion-exchanged

was not enough to attain equilibrium in 20 days, the pyridyl groups cohered on the membrane were 1.93 times the number of cation exchange groups of the membrane. If immersed for more than 20 days, the number of each N-dodecyl pyridyl compounds ultimately cohered would be the same. When the concentration was lower than  $0.0025 \text{ mol l}^{-1}$ , all the cations in the solution were completely adsorbed or ion-exchanged within 20 days. It was concluded that the large organic cations were selectively adsorbed or ion-exchanged thus exceeding the ion-exchange capacity of the membrane.

Figs 4 and 5 show the electroalytic desorption of  $\text{C}_{12}$ -Py and  $\text{C}_{12}$ -Dipy from the membrane.

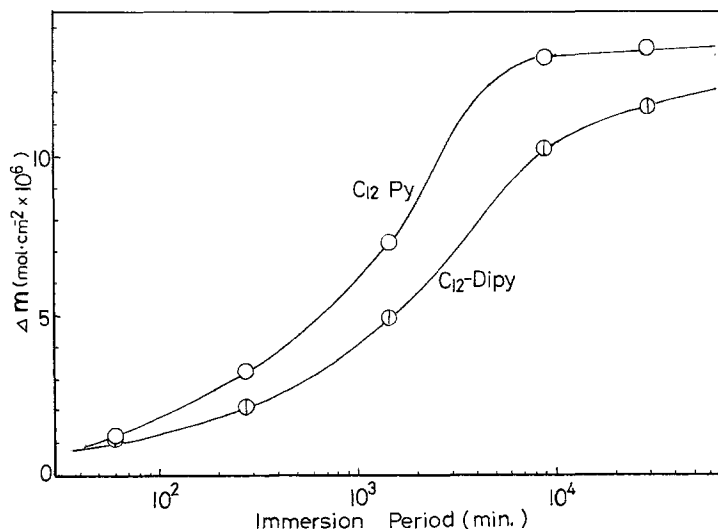

Fig. 3. Relationship between adsorbed or ion-exchanged amount of various N-dodecyl pyridyl compounds and immersion period. Concentration  $8 \times 10^{-3} \text{ mol l}^{-1}$ .

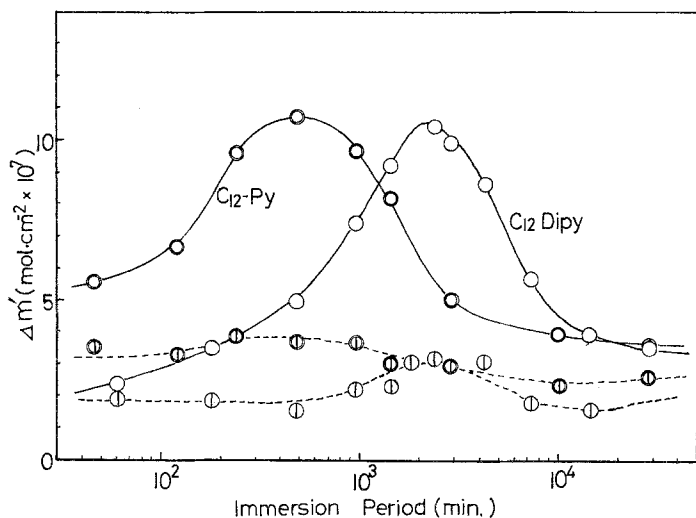

Fig. 4. Desorption of N-dodecyl pyridyl compounds from NEOSEPTA CL-25T by electro dialysis (I) following immersion in  $2.5 \times 10^{-3} \text{ mol l}^{-1}$  solution. ○, amount  $\text{C}_{12}$ -Dipy desorbed into catholyte; ⊙, amount  $\text{C}_{12}$ -Py desorbed into catholyte; ⊖, amount  $\text{C}_{12}$ -Dipy desorbed into anolyte; ⊕, amount  $\text{C}_{12}$ -Py desorbed into anolyte.

The amount desorbed and dissolved in the catholyte was larger than that in the anolyte. Figs 2 to 5 show that the amount of  $\text{C}_{12}$ -Py desorbed reached a maximum just before adsorption or ion-exchange equilibrium was attained, and then reduced. This means that the compounds adsorbed or ion-exchanged migrated into the pores of the membrane after equilibrium. In order to examine the detailed electro dialytic desorption, the electro dialysis was carried out five times using a membrane immersed for 20 days. In each electro dialysis, both anolyte and catholyte were renewed and the amounts of  $\text{C}_{12}$ -Py or  $\text{C}_{12}$ -Dipy in both compartments were determined (Table 3). The data in Table 3 show that more than 30% of the cations adsorbed

or ion-exchanged were remaining inside the membrane even after five times of electro dialysis. The electro dialytic desorption of  $\text{C}_{12}$ -Dipy was more difficult than that of  $\text{C}_{12}$ -Py. Thus, the large organic cations which attained adsorption or ion-exchange equilibrium with difficulty are also difficult to desorb from the membrane.

NEOSEPTA CL-25T is a sulphonated styrene-divinylbenzene type cation exchange membrane. The diffusion coefficient of glucose was about  $(0.8-1.3) \times 10^{-8} \text{ cm}^2 \text{ s}^{-1}$ , and that of sucrose was about 1/9 that of glucose. As the diameters of the glucose and the sucrose molecules are calculated by Stokes Einstein Equation [17] to be about 0.83 and 1.03 nm respectively, the pore

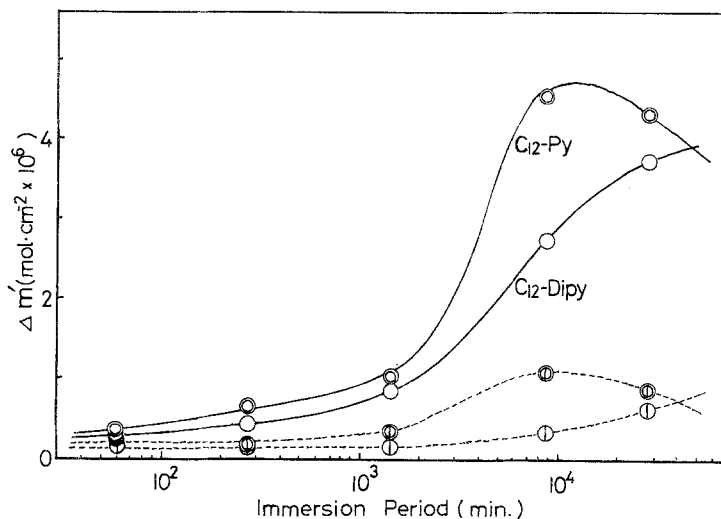

Fig. 5. Desorption of N-dodecyl pyridyl compounds from NEOSEPTA CL-25T by electro dialysis (II) following immersion in  $8 \times 10^{-3} \text{ mol l}^{-1}$  solution. Symbols as for Fig. 4.

Table 3. Desorption of *N*-dodecyl pyridyl compounds by electroanalysis

Number of electroanalysis	Direction of current	Concentration of $C_{12}$ -Py or $C_{12}$ -Dipy solution					
		$0.0025 \text{ mol dm}^{-3}$		$0.008 \text{ mol dm}^{-3}$		$C_{12}$ -Dipy	
		$C_{12}$ -Py $\Delta m \text{ (mol cm}^{-2}\text{)}$ $5.05 \times 10^{-6}$ $\Delta m' \text{ (mol cm}^{-2}\text{)}$	$C_{12}$ -Dipy $\Delta m \text{ (mol cm}^{-2}\text{)}$ $5.04 \times 10^{-6}$ $\Delta m' \text{ (mol cm}^{-2}\text{)}$	$C_{12}$ -Py $\Delta m \text{ (mol cm}^{-2}\text{)}$ $1.33 \times 10^{-5}$ $\Delta m' \text{ (mol cm}^{-2}\text{)}$	$C_{12}$ -Dipy $\Delta m \text{ (mol cm}^{-2}\text{)}$ $1.15 \times 10^{-5}$ $\Delta m' \text{ (mol cm}^{-2}\text{)}$	Catholyte	Anolyte
1	→	$3.52 \times 10^{-7}$	$3.60 \times 10^{-7}$	$4.34 \times 10^{-6}$	$8.72 \times 10^{-7}$	$3.73 \times 10^{-6}$	$6.17 \times 10^{-7}$
2	→	$2.36 \times 10^{-7}$	$1.66 \times 10^{-7}$	$1.30 \times 10^{-6}$	$3.83 \times 10^{-7}$	$9.74 \times 10^{-7}$	$2.34 \times 10^{-7}$
3	→	$2.04 \times 10^{-7}$	$2.40 \times 10^{-7}$	$9.10 \times 10^{-7}$	$2.25 \times 10^{-7}$	$6.29 \times 10^{-7}$	$2.10 \times 10^{-7}$
4	→	$1.86 \times 10^{-7}$	$1.88 \times 10^{-7}$	$5.81 \times 10^{-7}$	$1.94 \times 10^{-7}$	$3.79 \times 10^{-7}$	$1.94 \times 10^{-7}$
5	←	$2.82 \times 10^{-7}$	$2.99 \times 10^{-7}$	$1.85 \times 10^{-7}$	$2.55 \times 10^{-7}$	$2.68 \times 10^{-7}$	$1.76 \times 10^{-7}$
Residual amount		$2.79 \times 10^{-6}$	$2.97 \times 10^{-6}$	$4.06 \times 10^{-6}$	$4.09 \times 10^{-6}$		

NEOSEPTA CL-25T was immersed in the *N*-dodecyl pyridyl compounds solution of a given concentration for 20 days before the electroanalysis.

diameter of NEOSEPTA CL-25T is estimated to be 1.0 nm or a little larger. However,  $C_{12}$ -Tripy ion is about 1.6 nm wide with an alkyl tail about 2.1 nm long estimated by using bond distance data [18]. In general, when large ions are adsorbed on or ion-exchanged with ion exchange membranes, the membranes swell. This suggests that the adsorption or ion-exchange of the large ions caused an expansion of the polymer matrix. Studies on the adsorption of various pyridyl compounds on clay minerals show that lamellar collapse was observed by their adsorption [19, 20]. It can be seen from these phenomena that the large organic cations adsorb on, or ion-exchange with NEOSEPTA CL-25T exceeding the ion-exchange capacity. It is difficult to evaluate accurately the pore size of the ion exchange membrane because the polymer matrix is somewhat flexible.

Two mono-N-dodecyl pyridyl compounds were obtained in the reactions of dodecyl bromide with  $\alpha, \alpha'$ -dipyridine and with  $\alpha, \alpha', \alpha''$ -tripyridine. Accordingly, the adsorption and desorption behaviour should change depending on the pH of the solution. The data in Table 4 show that the amount desorbed from the membrane immersed in a basic solution was larger than that in an acidic solution, although the amount adsorbed or ion-exchanged was almost the same. The cations easily desorbed from the membrane immersed in the basic solution and

the electric resistance of the membrane in the initial stage of the electro dialysis was high compared with the membrane immersed in the acidic solution where the membrane would show its bipolar property. This suggests that the cations cohere on the outer surface mainly by adsorption. Measurements were also made with  $C_{12}$ -Tripy and similar results were obtained. It is well known that multivalent, rather than monovalent, cations are selectively ion-exchanged with cation exchange membranes. The results in Table 4 confirm that the large organic cation more easily adsorbs on or ion-exchanges with the membrane in its multivalent state than in its monovalent state.

### 3.2. Change in properties of cation exchange membranes by adsorption or ion-exchange of large organic cations

Fig. 6 shows the change in electro dialytic property of membranes of NEOSEPTA CL-25T which were immersed in dodecyl pyridinium chloride solutions of various concentrations for 16 h. The electric resistance of membranes during electro dialysis increased remarkably as the concentrations of the large organic cations increased, and reached a maximum, while  $P_{Na}^{Ca}$  decreased and reached a minimum, and the current efficiency gradually decreased. Fig. 7 also shows the change in electro dialytic property

Table 4. Desorption of N-dodecyl pyridyl compounds from a cation exchange membrane and properties of the membrane

Run number	pH of $C_{12}$ -Dipy solution	adsorbed or ion-exchanged amount ( $mol\ cm^{-2}$ )	desorbed* amount ( $mol\ cm^{-2}$ )	$P_{Na}^{Ca}$	c.e. (%)	$R(\Omega\ cm^2)$	
						initial	at 60 min
1	3.85	$3.19 \times 10^{-6}$	$\oplus 2.19 \times 10^{-7}$ $\ominus 7.35 \times 10^{-7}$	2.17	91.0	2386	55.3
2	12.0	$3.10 \times 10^{-6}$	$\oplus 2.07 \times 10^{-7}$ $\ominus 1.85 \times 10^{-6}$	2.02	91.0	2516	54.3
3	—	—	$\oplus 1.91 \times 10^{-7}$ $\ominus 8.51 \times 10^{-7}$	2.23	96.3	32.8	25.3

Run No. 1 shows the results of the electro dialysis after the membrane was immersed in an acidic solution of  $C_{12}$ -Dipy for 16 h.

Run No. 2 shows the results of the electro dialysis after the membrane was immersed in a basic solution of  $C_{12}$ -Dipy for 16 h (addition of NaOH).

Run No. 3 shows the results of the electro dialysis after the immersion of the membrane, used in Run No. 2, in an acidic mixed salt solution (0.208 N  $CaCl_2$  and 0.208 N NaCl at pH 3.26: addition of HCl) for 30 min.

\*  $\oplus$  and  $\ominus$  in column 4 denote anolyte and catholyte.

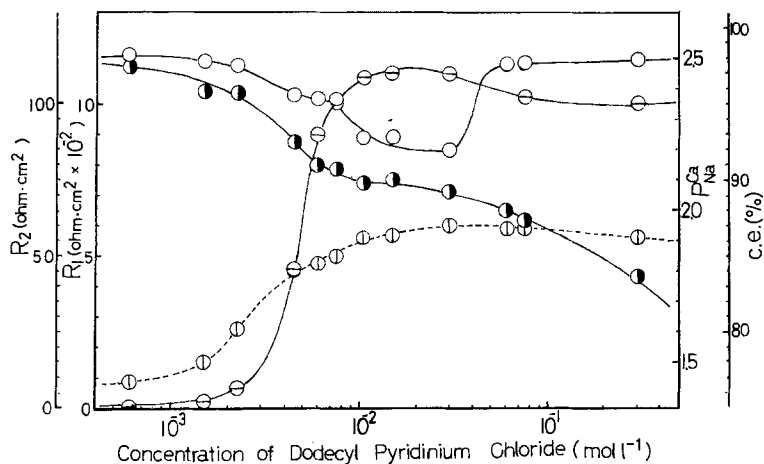

Fig. 6. Relationship between transport properties of NEOSEPTA CL-25T immersed in dodecyl pyridinium chloride solution and its concentration. (Immersion, 16 h.)  $\circ$ ,  $P_{Na}^{Ca}$ ;  $\bullet$ , current efficiency (%);  $\odot$ , electric resistance of the membrane at the beginning of electro-dialysis ( $R_1$ );  $\oplus$ , electric resistance of the membrane during electro-dialysis after 1 h ( $R_2$ ).

of a membrane of NEOSEPTA CL-25T by adsorption or ion-exchange of hexadecyl trimethylammonium chloride. Although the degree of change in properties was different the same tendency was observed. Figs 8 and 9 also show the same tendency. When the concentration was low or the immersion period was short, a monolayer of the large organic cations would be formed on the membrane surface, and the change in transport properties of the membrane would be small. However, when the concentration was high or the immersion period was long, cationic multilayers would be formed on the membrane surface and the cations partially entered the pores of the membrane. The large organic cations in the membrane work as an anion exchange group because of their low mobility in the membrane phase; therefore, the

current efficiency gradually decreased as the concentrations of the large organic cations and the immersion period increased. On the other hand, the electrostatic repulsion by the multilayers of cations should be smaller against the sodium ion than the calcium ion. The reason why the sodium ion permeates selectively through the membrane is ascribed to the electrostatic repulsion by the multilayers.

$P_{Na}^{Ca}$  showed the lowest value with hexadecyl trimethylammonium chloride (Figs 7 and 8). The cation density in the layer on the membrane surface would change during the electro-dialysis because the cations permeate through the membrane in an electric field. Thus,  $P_{Na}^{Ca}$  was an average value measured during the one hour electro-dialysis. To obtain a low value of  $P_{Na}^{Ca}$ , the cation density on the membrane surface should

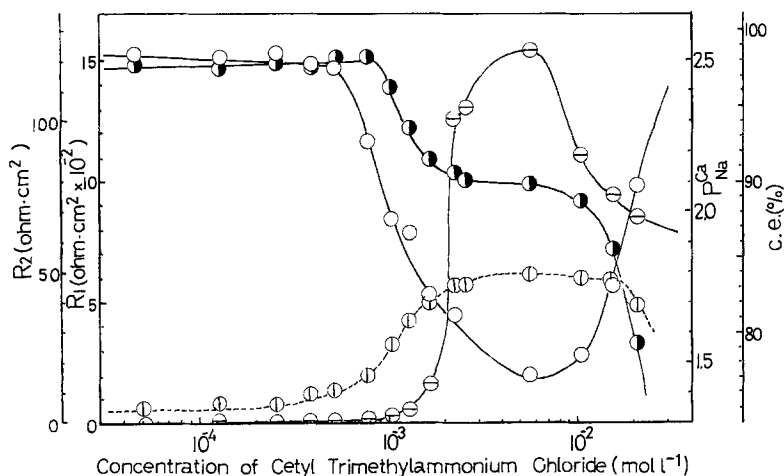

Fig. 7. Relationship between transport properties of NEOSEPTA CL-25T immersed in hexadecyl trimethylammonium chloride and its concentration. (Immersion 24 h.)  $\circ$ ,  $P_{Na}^{Ca}$ ;  $\bullet$ , current efficiency (%);  $\odot$ , electric resistance of the membrane at the beginning time of electro-dialysis ( $R_1$ );  $\oplus$ , electric resistance of the membrane during electro-dialysis after 1 h ( $R_2$ ).



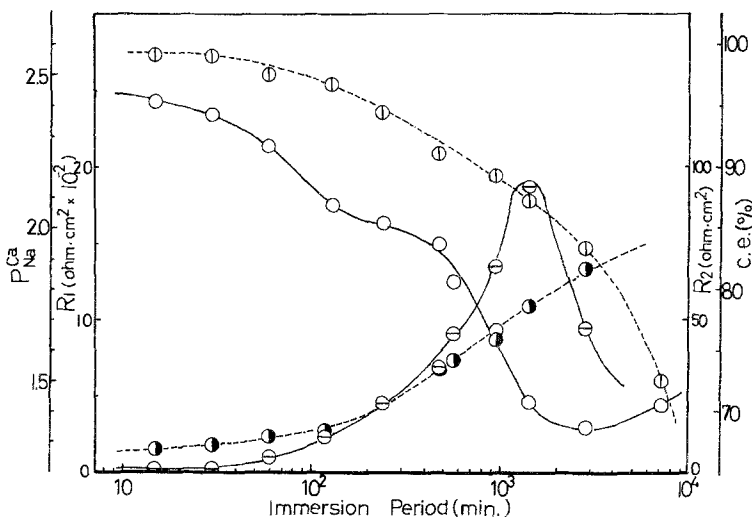

Fig. 8. Electroalytic transport properties of NEOSEPTA CL-25T immersed in hexadecyl trimethylammonium chloride solution. Concentration  $5.2 \times 10^{-3} \text{ mol l}^{-1}$ .  $\circ$ ,  $P_{Na}^{Ca}$ ;  $\oplus$ , current efficiency (%);  $\ominus$ , electric resistance of the membrane at the beginning time of electrolysis ( $R_1$ );  $\bullet$ , electric resistance of the membrane during electrolysis after 1 h ( $R_2$ ).

be high and the change in density should be small during the electrolysis. It is desirable that the membrane should strongly adsorb large organic cations so that the cations may hardly desorb from and permeate through the membrane, although their behaviour is dependent on their molecular structure. It has been reported in the study on the properties of aqueous surface active agents that the formation of micelles and their adsorption on interfaces becomes easier and their desorption from the interfaces becomes more difficult as the chain of their alkyl groups become longer. It is also said that the higher the molecular weight of the surface active agent, the more difficult their permeation through the membrane.

It is apparent from Fig. 8 that hexadecyl trimethylammonium chloride shows a decrease in  $P_{Na}^{Ca}$  which reached 1.36, although hexadecyl pyridinium chloride reached a  $P_{Na}^{Ca}$  of 1.90 at the minimum reported in the previous paper [1]. The aggregation numbers of micelles in the aqueous solutions of surface active agents have been studied by many investigators [21–25]. Venable and Nauman [21] have reported that the aggregation numbers are 81 and 73 in solutions of tetradecyl pyridinium bromide and tetradecyl trimethylammonium bromide and the critical micelle concentrations (CMCs) are  $2.57 \times 10^{-3}$  and  $3.51 \times 10^{-3} \text{ mol l}^{-1}$  in water, respectively. Anacker *et al.* (22–24) have also reported that the aggregation numbers are 51 and 48 for

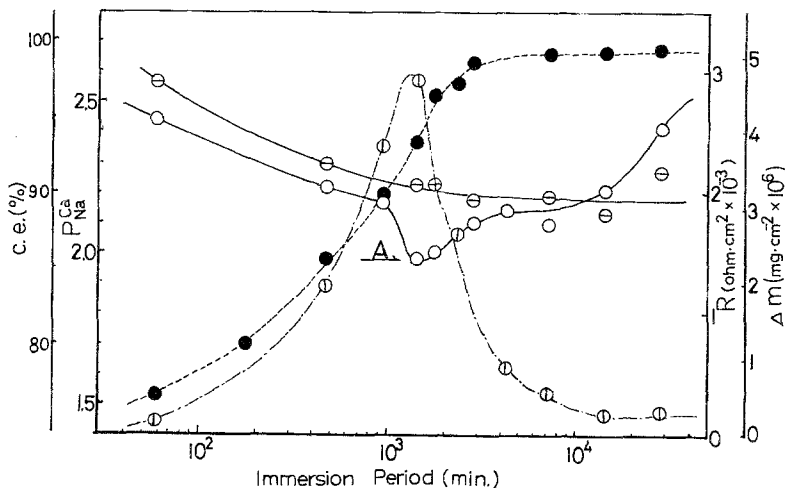

Fig. 9. Electroalytic transport properties of NEOSEPTA CL-25T immersed in C<sub>12</sub>-Dipy solution. Concentration  $2.5 \times 10^{-3} \text{ mol l}^{-1}$ .  $\circ$ ,  $P_{Na}^{Ca}$ ;  $\oplus$ , current efficiency (%);  $\ominus$ , electric resistance of the membrane at the beginning time of electrolysis;  $\bullet$ ,  $\Delta m$ .

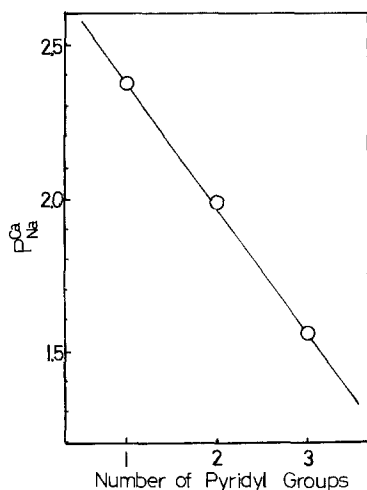

Fig. 10. Relationship between minimum value of  $P_{Na}^{Ca}$  (A value) and number of pyridyl groups in N-dodecyl pyridyl compounds.

micelles of decyl pyridinium bromide and decyl trimethylammonium bromide and the CMCs are  $1.6 \times 10^{-2}$  and  $1.8 \times 10^{-2} \text{ mol kg}^{-1}$  in 0.5 M bromide solution, respectively. These data suggest that the hexadecyl pyridinium ions aggregate more easily than the hexadecyl trimethylammonium ions: the hexadecyl pyridinium ions would form cation multilayers on the membrane surface more easily than the hexadecyl trimethylammonium ions. Nevertheless, the minimum value of  $P_{Na}^{Ca}$  with hexadecyl trimethylammonium chloride was lower than that with hexadecyl pyridinium chloride, which suggests that the hexadecyl pyridinium ions

would desorb more easily from and permeate through the membrane than would the hexadecyl trimethylammonium ions. Thus, the large organic cations,  $C_{12}$ -Dipy and  $C_{12}$ -Tripy, were used in the measurements. Fig. 9 shows the relationship between the immersion period with  $C_{12}$ -Dipy on the membrane and the change in transport properties. The same measurements were made with the  $C_{12}$ -Py and  $C_{12}$ -Tripy solution. Fig. 10 shows that the minimum value of  $P_{Na}^{Ca}$  decreases linearly and the permeation through the membrane becomes difficult as the number of pyridyl groups of the compounds increases.

High electric resistance of the membrane which was caused by the adsorption or ion-exchange decreased during electro dialysis. A typical example is shown in Fig. 11. When the immersion period was relatively short so that no equilibrium was attained, the electric resistance was remarkably high at the initial stage of the electro dialysis and then decreased sharply: while the electric resistance was rather low at the initial stage and gradually decreased during the electro dialysis after adsorption or ion-exchange equilibrium was attained.

It is suggested that the cation exchange membrane has the same properties as bipolar ion exchange membranes before adsorption or ion-exchange equilibrium, and that it has those of the amphoteric after equilibrium is attained. These phenomena can be explained in Fig. 12: the electric resistances of the membranes used in the measurements shown in Fig. 3 were

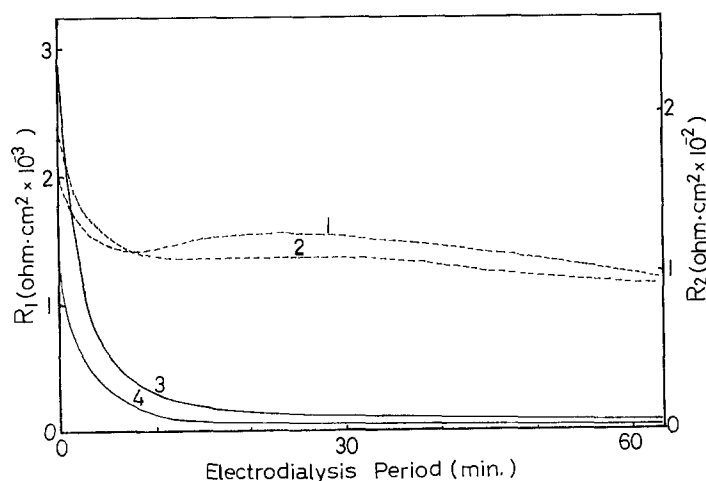

Fig. 11. Change in electric resistance of NEOSEPTA CL-25T immersed in aqueous  $C_{12}$ -Dipy solution during electro dialysis. The immersion period of the membrane was varied as follows: 1, 240 h; 2, 480 h; 3, 24 h; 4, 8 h. Curves 1 and 2 refer to  $R_2$  of vertical axis; curves 3 and 4 refer to  $R_1$  of vertical axis. The concentration of  $C_{12}$ -Dipy was  $2.5 \times 10^{-3} \text{ mol l}^{-1}$ .

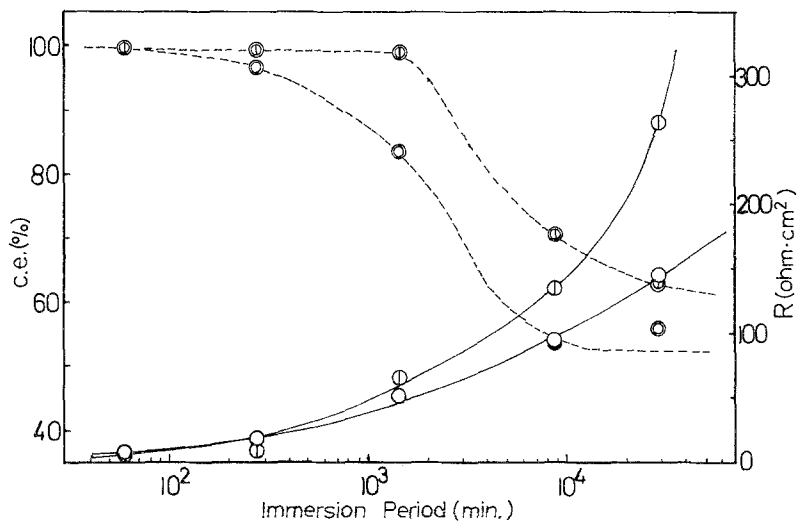

Fig. 12. Relationship of electric resistance of the membrane ( $R$ ) (measured by a.c.) and current efficiency ( $c.e.$ ) to the immersion period.  $\circ$ , values of  $R$  for  $C_{12}$ -Py;  $\odot$ , values of  $c.e.$  for  $C_{12}$ -Py;  $\oplus$ , values of  $R$  for  $C_{12}$ -Dipy;  $\ominus$ , values of  $c.e.$  for  $C_{12}$ -Dipy. The current efficiency was measured by electrolysing the same membrane as used in measurements of Fig. 3. The electric resistance of the membrane was measured by 1000 cycle a.c. before electro dialysis by using a mixed solution composed of 0.208 N  $CaCl_2$  and 0.208 N  $NaCl$ .

obtained by applying an alternating current to a solution of 0.208 N  $NaCl$  and 0.208 N  $CaCl_2$ . The electric resistance increased as the immersion period increased, but did not show any peak values as shown in Fig. 9. Although the electric resistance at the beginning of electro dialysis was about  $1500 \Omega cm^{-2}$  with the membrane immersed in a solution of  $C_{12}$ -Py for 20 days and  $1350 \Omega cm^{-2}$  with that in a solution of  $C_{12}$ -Dipy, the

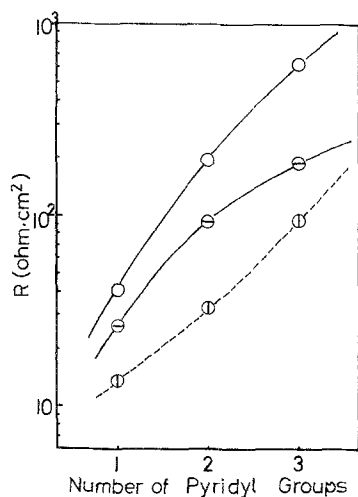

Fig. 13. Relationship between electric resistance of NEOSEPTA CL-25T during electro dialysis and number of pyridyl groups in N-dodecyl pyridyl compounds.  $\circ$ , at the beginning of electro dialysis;  $\odot$ , at 60 min electro dialysis;  $\oplus$ , at 60 min during fourth electro dialysis. NEOSEPTA CL-25T was immersed in various N-dodecyl pyridyl compounds solution of  $2.5 \times 10^{-3} mol l^{-1}$  for  $2.88 \times 10^4$  min (20 days). Period of each electro dialysis was 60 min.

electric resistance measured with the alternating current was  $145 \Omega cm^{-2}$  with the former and  $275 \Omega cm^{-2}$  with the latter. The remarkably high electric resistance produced during the electro dialysis was mainly due to the desalination of the intermediate layer between the cation multilayers and the membrane surface. However, change in pHs of both anolyte and catholyte was not observed after electro dialysis. Fig. 13 also shows that the electric resistance of the membrane increased with increasing the number of pyridyl groups of the compounds.

It was the large hydrophobic groups of surface active agents that entered the pores of the membrane; therefore, it is expected that the membrane became more hydrophobic and its water content decreased accordingly. It is shown in Fig. 14, where NEOSEPTA CL-25T was immersed in an aqueous solution of dodecyl pyridinium chloride of  $3.0 \times 10^{-2} mol l^{-1}$  with stirring at  $25.0^\circ C$  that its water content decreased remarkably. Another membrane was immersed in a dodecyl pyridinium chloride solution for 20 days under the same condition, and its water content was found to be 14.5%. It is shown in Fig. 14 that the water content measured suggests that an equilibrium was attained in two days. The pores of the membrane were plugged by the large organic cations as evidenced by a change in apparent diffusion coefficient of sodium chloride. Fig. 14 shows that the apparent diffusion coefficient of sodium chloride

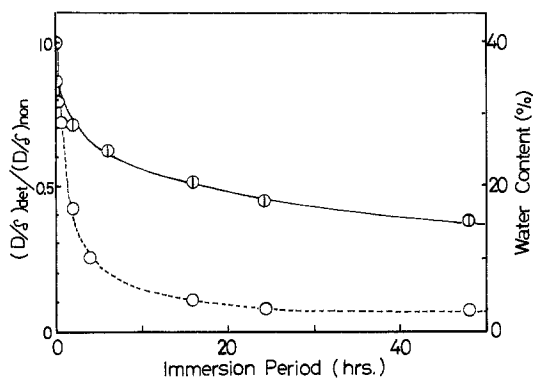

Fig. 14. Decrease in apparent diffusion coefficient and water content of NEOSEPTA CL-25T by means of adsorption and ion-exchange of dodecyl pyridinium chloride.  $\circ$ ,  $(D/\delta)$  det./  $(D/\delta)$  non;  $\Phi$ , water content. The apparent diffusion coefficient was measured between 4.0N sodium chloride solution and pure water under stirring at 25.0°C after NEOSEPTA CL-25T had been immersed in an aqueous dodecyl pyridinium chloride solution of  $3.0 \times 10^{-2} \text{ mol l}^{-1}$  for a given period.  $D$ , apparent diffusion coefficient;  $\delta$ , membrane thickness;  $(D/\delta)$  non, without dodecyl pyridinium chloride;  $(D/\delta)$  det., with dodecyl pyridinium chloride.

decreased remarkably with increase of the immersion period of the membrane in the dodecyl pyridinium chloride solution.

Fig. 12 also shows the current efficiency of the membranes used in the measurements shown in Fig. 3. The current efficiency of the membrane immersed for 20 days was about 60%. As the amount adsorbed or ion-exchanged exceeded the ion-exchange capacity of the membrane, it was expected that the membrane had anion permselectivity. However, Table 3 shows that about 40% of dodecyl pyridyl compounds desorbed from the membrane after the electro-dialysis of one hour (39.2% of  $C_{12}$ -Py and 37.8% of  $C_{12}$ -Dipy). Accordingly, the current efficiency shown in Fig. 12 also represents an average value over 1 h of electro-dialysis.

## References

- [1] T. Sata, R. Izuo, Y. Mizutani and R. Yamane, *J. Colloid Interface Sci.* **40** (1972) 317.
- [2] T. Sata, *Electrochimica Acta* **18** (1973) 199.
- [3] T. Sata, R. Izuo and Y. Mizutani, *Soda to Enso* (Soda and Chlorine) **35** (1984) 313.
- [4] E. J. H. Kobus and P. M. Heerjes, *Desalination* **12** (1973) 333.
- [5] Y. Mizutani, R. Yamane, T. Sata and R. Izuo, Japanese Patent Application Publication No. 4352 (1975) (Application Date: September 14, 1970); US. Patent 3784457.
- [6] H. C. Heller and V. Markovac, *Anal. Chem.* **55** (1983) 551A.
- [7] K. Kusumoto and Y. Mizutani, *Desalination* **17** (1975) 111.
- [8] K. Kusumoto, Y. Mizumoto and Y. Mizutani, *ibid.* **17** (1975) 303.
- [9] T. Sata, *Colloid Polymer Sci.* **256** (1978) 62.
- [10] K. Kusumoto, *Nippon Kaisui Gakkaishi* (Bulletin of the Society of Sea Water Science) **33** (1979) 143.
- [11] C. R. Martin, I. Rubinstein and A. Bard, *J. Amer. Chem. Soc.* **104** (1982) 4817.
- [12] Y. Mizutani, R. Yamane, H. Ihara and H. Motomura, *Bull. Chem. Soc. Jpn.* **36** (1963) 361.
- [13] Y. Mizutani, R. Yamane and H. Motomura, *ibid.* **38** (1965) 689.
- [14] Y. Mizutani, W. Teshima and S. Akiyama, Japanese Patent Application Publication No. 368 (1966); Y. Mizutani, R. Yamane and H. Motomura, Japanese Patent Application Publication No. 8778 (1969) etc.
- [15] Y. Mizutani, W. Teshima, S. Akiyama, R. Yamane and H. Ihara, US Patent 3451951 (1969).
- [16] M. Kotake, "Dai-Yūkikagaku" (Complete Organic Chemistry), "Yūkikagaku-Jōsū-Binran" (Handbook of Constants in Organic Chemistry) II (Asakura Shoten, Tokyo, 1963) p. 598.
- [17] L. Friedman and P. G. Carpenter, *J. Amer. Chem. Soc.*, **61** (1939) 1745.
- [18] Kagaku-Binran, "Kisohen" (Handbook of Chemistry, Basic Volume) II, edited by Chemical Society of Japan (1966) p. 1225.
- [19] R. Green-Kelly, *Trans. Faraday Soc.* **51** (1955) 412.
- [20] M. H. B. Hays, M. E. Pick and B. A. Toms, *J. Colloid Interface Sci.* **65** (1978) 254.
- [21] R. L. Venable and R. V. Nauman, *J. Phys. Chem.* **68** (1964) 3498.
- [22] R. D. Geer, E. H. Eylar and E. W. Anacker, *ibid.* **75** (1971) 369.
- [23] E. W. Anacker and R. D. Geer, *J. Colloid Interface Sci.* **35** (1971) 441.
- [24] P. T. Jacobs and E. W. Anacker, *ibid.* **44** (1973) 505.
- [25] E. Roelants, E. Geladé, M. Van Der Auweraer, Y. Croonen and F. C. de Schryver, *ibid.* **96** (1983) 288.